



**R410A**



# WATER-COOLED SCROLL CHILLER (HEAT PUMP)

TICA Central Air Conditioner

## Established in 1991,

TICA is a professional enterprise specialized in R&D, manufacturing, sales and services of environment cleaning and thermal energy utilization.

TICA is a national high-tech enterprise, a single leading enterprise cultivated by the Ministry of Industry and Information Technology, a national brand cultivation enterprise of the Ministry of Industry and Information Technology, and a vice chairman member of China Refrigeration and Air-conditioning Industry Association. It has a national-recognized enterprise technology center, an enterprise academician workstation, and a post-doctoral research workstation. Its projects cover Beijing Bird's Nest Stadium, Water Cube, Wukesong Indoor Stadium, PetroChina, Sinopec, State Grid, Nanjing Panda, Hangzhou Xiaoshan International Airport, Hainan Airlines Group, Shangri-La Hotel, Manila Ocean Park, Abu Dhabi Al Muneera, SM City in Philippines and Unilever, etc.

TICA is also the outstanding provider of central air conditioners for China's subway networks and has successfully served nearly 60 key subway lines in major cities such as Beijing, Shanghai, Guangzhou, Shenzhen, Chengdu, Suzhou, Hangzhou and Tianjin. TICA is a professional supplier and service provider in China that specializes in system integration of clean environment. While for microelectronics, hospital operating rooms, biopharmaceutical industry and other professional purification areas, our market share has achieved over 40% in each.

## TICA Quality For IAQ

TICA focuses on indoor air quality (IAQ) in clean environments. Product lines include return air purifiers, heat recovery ventilators, fresh air purifiers, air purifiers, as well as the clean air handling units and digital variable-capacity air handling units used in the professional purification field. Regarding core technology, TICA established an ISO class 1 super-clean environment integration system and won the first prize of CMIST.

In the field of thermal energy utilization, TICA's product lines include modular chillers, VRF units, screw chillers, centrifugal chillers, and ORC low-temperature waste heat power generation systems. In 2015, TICA and United Technologies Corporation (UTC) established a global strategic joint venture cooperation relationship and acquired PureCycle, an ORC low-temperature power generation company owned by Pratt & Whitney under UTC. TICA obtained PureCycle trademarks and more than 100 patents and national copyrights. TICA's efficient centrifugal chillers, water-cooled screw chillers, and air-cooled screw chillers are manufactured with the technical license of Carrier under UTC.

TICA is characterized by excellent system integration capability. In the application of "Efficient Refrigeration System of Underground Railway Station", the integrated COP of the refrigeration room amounts to 6.0, and the research achievement reaches the international advanced level. In 2018, TICA merged and acquired an OFC central air conditioning enterprise **SMARTD**. TICA's excellent system integration capability and the **SMARTD** world-class OFC water chillers help increase the integrated COP of the efficient equipment room to 6.7 to -7.0.

TICA---We're striving.

TICA aims to build itself into a world-leading system integration supplier and service provider that specializes in clean environment and thermal energy utilization.



## WATER-COOLED SCROLL CHILLER (HEAT PUMP) Contents

Overview	4
Nomenclature	4
Performance Characteristics	5
Performance Specifications of Cooling-only Unit	8
Performance Parameters of Water Source Heat Pump Unit (Underground Water)	8
Performance Parameters of Water Source Heat Pump Unit (Geothermal)	9
Recommended Glycol Solution Concentration	9
Corrected Technical Parameters under Variable Operating Condition	10
Module Dimensions	12
Unit Assembly Diagram	14
Position and Dimensions of Installation Foundation	15
Instruction for Use	15
External Water Pipe Connection Diagram of Unit	16
Five-year Warranty. Quality Assured	17

TICA owns five production sites in Nanjing, Tianjin, Guangzhou, Chengdu and Kuala Lumpur, and a network of over 70 sales and service filiales around the world.

Its Nanjing HQ base received 3-star certification for national No. 001 green industrial construction.



Nanjing Headquarter



Tianjin Base



Guangzhou Base



Chengdu Base

# TICA environment-friendly water-cooled scroll-type TWS series specially recommended for small-to-mid-sized buildings

## For customers, the product is featured by...



### High efficiency & energy saving

- High EER, higher energy efficiency at partial load, saving the operation cost for the user.
- Due to modular operation, hierarchical startup saves energy



### Healthy and comfortable

- The unit adopts the world-renowned hermetic scroll compressor, which runs quietly with low vibration.
- The unit can quickly and accurately meet the requirements of the user thanks to its superior control and powerful operation of the compressor.



### Reliable and stable

- The modular design allows starting the units in a hierarchical way, reducing the impact of the startup current on the power grid.
- The unit is equipped with a variety of protection functions to ensure safe operation.
- The designed service life is long, protecting customer's investment.



### Flexible and user-friendly

- Units can be purchased and installed by stages according to the actual need; thanks to the compact structure, the units do not need a special equipment room and can be installed on rooftop.
- The modular structure facilitates maintenance. Units are not affected when one unit is repaired or maintained.
- Units can be controlled in a centralized manner to facilitate routine management. The operation interface is user-friendly and meets various needs.



# For **designing institutes** and **installation**, the product is featured by...

## Environmental-friendly

- The unit adopts the environmental-friendly refrigerant HFC-410A, which is safe for the ozone layer and not subject to any restriction for use. It is highly appealing to designers advocating environmental protection.
- Outstanding cooling performance, low power consumption, low emission of CO<sub>2</sub> emissions.



## Easy unit selection

- The unit has three basic unit modules: 20RT, 30RT and 40RT, which can serve as an arbitrary combination of the master unit and the slave units. At most 12 units can be combined with a combined capacity of 20RT to 480RT at an interval of 10RT, facilitating the selection of units.

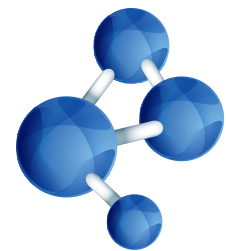

## Easy handling

- The modules can be handled by elevator or forklift. No professional hoist is needed, thus saving the hoisting and labor costs.



## Convenient Installation

- The unit can be transported separately, combined and installed conveniently and simply, thus shortening the installation period.

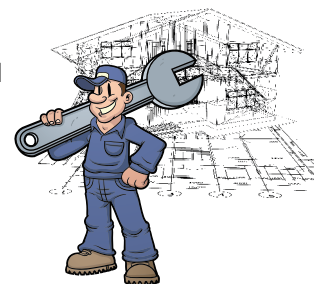

Designing  
institutes

## WATER-COOLED SCROLL CHILLER (HEAT PUMP) Overview

TICA New R410A water-cooled scroll chiller (heat pump) is an environmental-friendly, efficient and energy-saving product. The unit adopts the industry-leading technology and experience, optimizes the heat exchange technology to improve the EER, and balances between environmental impacts and economic benefits. It is the best choice for cooling or process cooling with central air conditioning and a new generation of environmental-friendly high efficiency scroll chiller developed by TICA. The unit not only provides a wide range of cooling capacity, low operating costs, but is also very environmental-friendly.

This series of units adopt advanced hermetic scroll compressors and high-efficiency compact heat exchangers. With advanced microcomputer control technology and modular refrigeration regulation technology, the unit not only realizes a higher EER, but also achieves remarkable energy saving, stability and reliability. In addition, it effectively reduces the initial investment and saves operating costs for the user.

The product has a wide scope of cooling capacity. For a small-capacity-range application, a single module can be selected and used. Multiple modules can be combined and used to meet the need for a larger capacity range (at most 12 modules can be combined). Two combination ways are provided: 20, 30RT mixed assembly and 40RT separate assembly. The unit is easy-to-install, compact, quiet with a low maintenance cost and small footprint. It can be widely used in high-end villas, hotels, hospitals, office buildings, entertainment venues, restaurants, schools and industrial cooling applications.



## Nomenclature

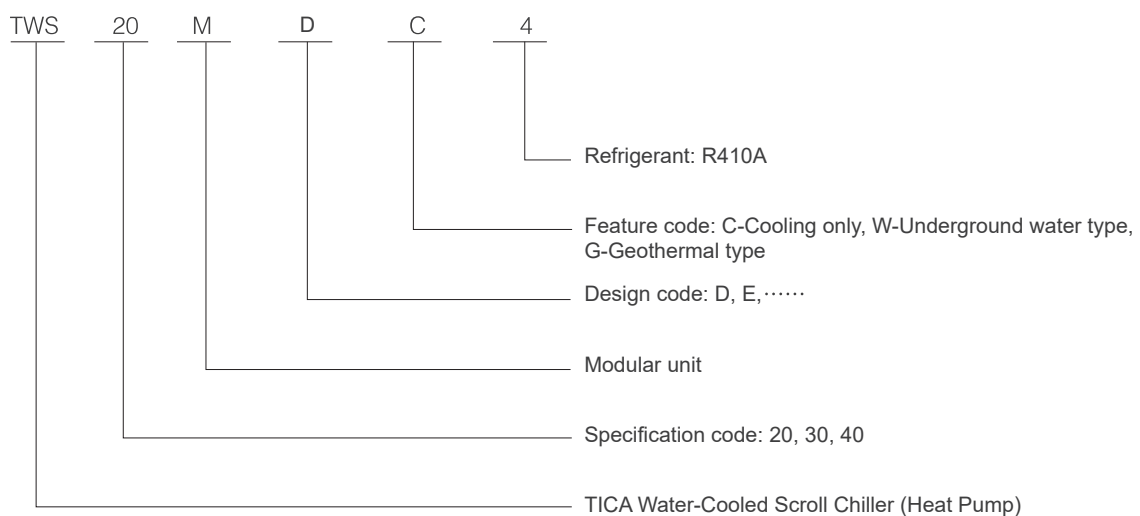

## Performance Characteristics

WATER-COOLED SCROLL CHILLER (HEAT PUMP)

### High Efficiency & Energy Saving

#### ■ Compressor

The units adopt the high-efficiency scroll compressors from a world-famous manufacturer. The compressor is featured by a small clearance capacity, small friction loss and high operation efficiency. Each modular unit is equipped with two scroll compressors. The combination of multiple modules provides multi-level capacity regulation, which is more energy efficient under operation with partial load.

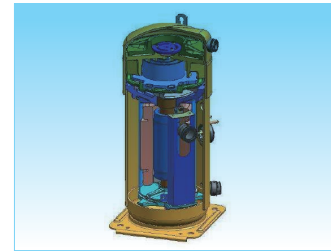

#### ■ Condenser and evaporator

It adopts the high-efficiency shell-and-tube heat exchanger with high-efficiency inner grooved copper tube, which improves the heat exchange efficiency; the heat exchange area is increased to lower the heat exchange temperature difference and improve the unit's COP; the condenser is equipped with a supercooling section at the bottom to effectively improve the supercooling of the refrigerant liquid; the modern manufacturing process and technologies ensure that the container is clean and free of impurities, thus improving the heat exchange efficiency; the heat exchanger undergoes strict flaw detection test and pressure inspection to ensure safety and reliability.

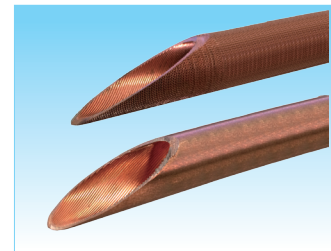

#### ■ Cooling accessories

The expansion valve and protection control components all come from world-renown suppliers with reliable quality, ensuring that the unit can operate under high efficiency for a long time.

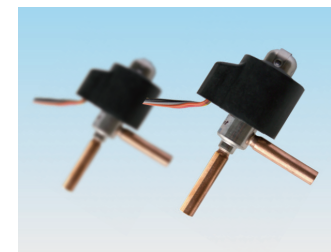

#### ■ Low operation noise

The unit has outstanding configuration and optimized design. Components are carefully compared, selected and optimized; the structure and pipeline are optimized to lower the noise. The unit has undergone the noise test in a precision noise lab.

- Hermetic scroll compressor with small vibration from a world-famous supplier;
- Flexible installation base for the compressor, minimizing the vibration of the compressor;
- Optimized air suction and discharge pipelines, reducing the vibration of the unit.



■ The modular structure improves the power efficiency of the unit

Each module unit provides 2 energy regulation levels. Modules combined provide more energy regulation levels;  
 The intelligent compressor operation balancing technology elevates the efficiency of the compressor with low load and saves energy for continuous operation;  
 When one compressor fails, the failure has no impact on the other units;  
 The modules can be combined in various ways and operate independently.

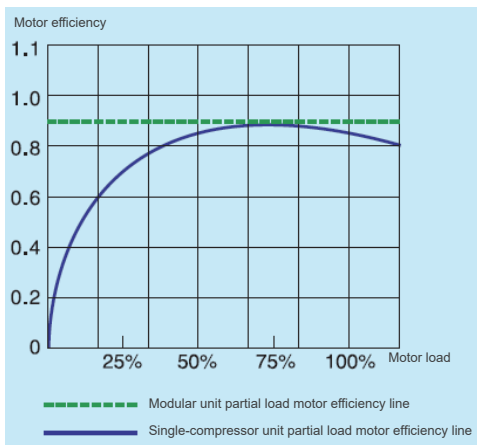

Recommended combination way

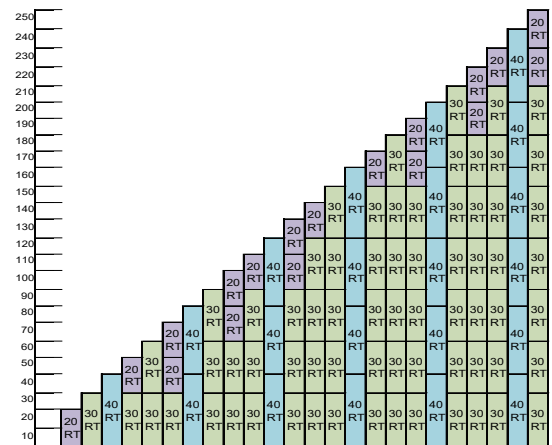

■ Multiple protection functions

The stability of air conditioner is very important for industrial and commercial users. TICA environmental-friendly water-cooled scroll chiller (heat pump) has been tested for a long time under conditions stricter than the national standard. The test result outperforms the national standard. The unit provides multiple protection technologies to ensure the normal operation, a long service life and safety of the unit.

- Phase sequence protection
- Frequent startup protection of the compressor
- Compressor overload protection
- Discharge temperature protection
- High and low pressure protection
- Disconnection protection
- Automatic freezing protection
- Automatic alarm and reset for some faults
- Automatic loading and unloading
- Powerful external interlocking





## Intelligent Control

The unit is equipped with a user-friendly operation interface to meet various operational requirements of customers. The unit is equipped with microcomputer monitoring, which can realize various functions such as temperature control, time setting, memory, status display, alarm display, temperature setting and group control. The user can use its own control switch to control the unit and use external switches to realize remote control.



### ■ Alarm and protection functions

- 17 protection and fault protection functions
- Button lock
- Password protection parameter setting

### ■ Parameter setting functions

- Real-time settings
- Timed power-on/off setting
- Cooling water inlet/outlet temperature setting
- Heating water inlet/outlet temperature setting

### ■ Basic operation functions

- Cooling mode
- Heating mode

### ■ Other functions

- Historical failure check
- Remote control on/off
- The battery supports running of the real-time clock upon power-off

### ■ Intelligent control of signal output

- Cooling water pump control output
- Chilled water pump control output

### ■ Parameter display function

- Operating status check
- Compressor operation status display
- Chilled water temperature display
- Hot water temperature display
- Water pump operation status display
- Freezing protection display
- Communication indicator
- Displaying information under multi-color backlight
- Error code

## WATER-COOLED SCROLL CHILLER (HEAT PUMP) Specifications

### Performance Specifications of Cooling-only Unit

Model TWS-MDC4	Cooling capacity kW	Power input kW	Compressor quantity	Number of energy regulation levels	Shell-and-tube evaporator				Shell-and-tube condenser			
					Water flow m <sup>3</sup> /h	Water pressure drop kPa	Connection mode	Water pipe diameter	Water flow m <sup>3</sup> /h	Water pressure drop kPa	Connection mode	
20	74.4	14.9	2	0-100%, 2 levels	DN50	12.8	39	Flexible clamp	DN65	16.0	24	Flexible clamp
30	112.2	22.4	2	0-100%, 2 levels	DN50	19.3	47		DN65	24.1	48	
40	146.3	29.2	2	0-100%, 2 levels	DN65	25.2	60		DN80	31.5	82	

Model TWS-MDC4	Compressor Type	Startup mode	Maximum running current A	Dimensions			Refrigeration system				Lubricant model	Weight	
				Length (mm)	Width (mm)	Height (mm)	Refrigerant	System quantity	Control mode	Charge amount kg		Shipping weight	Operating weight
20	Hermetic scroll compressor	Direct starting	48.0	1880	660	1380	R410A	2	EXV	12	RL32-3MAF	470	500
30			71.9	1880	660	1490		2		14.5		520	555
40			95.8	1880	740	1590		2		18		630	670

**Notes:**

- The above data is obtained based on nominal conditions of the unit: inlet/outlet chilled water temperature 12/7°C; inlet/outlet cooling water temperature 30/35°C;
- Power supply: 380V 3N-50Hz; allowable voltage fluctuation: ±10%;
- If other related parameters of the unit are needed, contact the factory;
- The specifications are subject to change due to product improvement without prior notice.

### Performance Parameters of Water Source Heat Pump Unit (Underground Water)

Model TWS-MD W4	Cooling capacity kW	Heating capacity kW	Cooling power input kW	Heating power input kW	Compressor Qty	Number of energy regulation levels	Cold and hot water-side heat exchanger				Underground water-side heat exchanger			
							Water pipe diameter	Water flow m <sup>3</sup> /h	Water pressure drop kPa	Connection mode	Water pipe diameter	Water flow m <sup>3</sup> /h	Water pressure drop kPa	Connection mode
20	78.3	83.4	13.6	18.3	2	0-100%, 2 levels	DN50	13.5	40	Flexible clamp	DN65	8.1	7	Flexible clamp
30	116.5	127.0	20.3	28.2	2	0-100%, 2 levels	DN50	20.0	49		DN65	12.0	13	
40	150.0	163.9	26.4	36.1	2	0-100%, 2 levels	DN65	25.8	63		DN80	15.5	22	

Model TWS-MD W4	Compressor Type	Startup mode	Maximum running current A	Dimensions			Refrigeration system				Lubricant model	Weight	
				Length (mm)	Width (mm)	Height (mm)	Refrigerant	System quantity	Control mode	Charge amount kg		Shipping weight	Operating weight
20	Hermetic scroll compressor	Direct starting	48.0	1880	660	1380	R410A	2	EXV	12	RL32-3MAF	470	500
30			71.9	1880	660	1490		2		14.5		520	555
40			95.8	1880	740	1590		2		630		670	

**Notes:**

- The above data is obtained based on nominal conditions of the unit:  
Cooling mode: inlet/outlet chilled water temperature 12/7°C; inlet/outlet underground water temperature 18/29°C;  
Heating mode: outlet hot water temperature 45°C; inlet underground water temperature 15°C;
- Power supply: 380V 3N-50Hz; allowable voltage fluctuation: ±10%;
- If other related parameters of the unit are needed, contact the factory;
- The specifications are subject to change due to product improvement without prior notice

## Performance Parameters of Water Source Heat Pump Unit (Geothermal)

Model TWS-MD G4	Cooling capacity kW	Heating capacity kW	Cooling power input kW	Heating power input kW	Compressor Qty	Number of energy regulation levels	Cold and hot water heat exchanger				Underground water loop heat exchanger			
							Water pipe diameter	Water flow m <sup>3</sup> /h	Water pressure drop kPa	Connection mode	Water pipe diameter	Water flow m <sup>3</sup> /h	Water pressure drop kPa	Connection mode
20	75.6	81.2	13.7	18.3	2	0-100%, 2 levels	DN50	13.0	40	Flexible clamp	DN65	16.3	25	Flexible clamp
30	113.4	121.2	20.5	28.1	2	0-100%, 2 levels	DN50	19.5	48		DN65	24.4	50	
40	149.2	154.2	27.1	36.0	2	0-100%, 2 levels	DN65	25.7	63		DN80	32.1	87	

Model TWS-MD G4	Compressor Type	Startup mode	Maximum running current A	Dimensions			Refrigeration system				Lubricant model	Weight	
				Length (mm)	Width (mm)	Height (mm)	Refrigerant	System quantity	Control mode	Charge amount kg		Shipping weight	Operating weight
20	Hermetic scroll compressor	Direct starting	48.0	1880	660	1380	R410A	2	EXV	12	RL32- 3MAF	470	500
30			71.9	1880	660	1490		2		14.5		520	555
40			95.8	1880	740	1590		2		18		630	670

### Notes:

- The above data is obtained based on nominal conditions of the unit  
Cooling mode: inlet/outlet chilled water temperature 12/7°C; inlet/outlet geothermal water temperature 25/30°C;  
Heating mode: outlet hot water temperature 45°C; inlet geothermal water temperature 10°C;
- When the outlet geothermal water temperature is lower than 3°C, glycol solution needs to be added. Refer to Recommended Glycol Solution Concentration for details;
- Power supply: 380V 3N-50Hz; allowable voltage fluctuation: ±10%;
- If other related parameters of the unit are needed, contact the factory;
- The specifications are subject to change due to product improvement without prior notice.

## Recommended Glycol Solution Concentration

Water Outlet Temperature °C	3 ~ 0	0 ~ -5	-5 ~ -10
Recommended Mass Concentration %	20	25	35

## Corrected Technical Parameters of Cooling-only Unit under Variable Operating Condition

Model	Chilled water outlet temperature °C	Cooling water inlet temperature °C							
		20		25		30		35	
		Cooling capacity	Power input	Cooling capacity	Power input	Cooling capacity	Power input	Cooling capacity	Power input
TWS-MDC4	5	1.026	0.813	0.980	0.895	0.931	0.999	0.874	1.123
	6	1.060	0.814	1.017	0.897	0.966	1.000	0.905	1.123
	7	1.095	0.817	1.052	0.898	1.000	1.000	0.940	1.123
	8	1.132	0.818	1.086	0.899	1.034	1.001	0.974	1.123
	9	1.169	0.821	1.123	0.902	1.072	1.003	1.009	1.124
	10	1.206	0.824	1.160	0.904	1.106	1.004	1.046	1.124

## Corrected Technical Parameters of Water Source Heat Pump Unit under Variable Cooling Operating Condition (Underground Water)

Model	Chilled water outlet temperature °C	Underground water inlet temperature °C											
		13		15		18		20		23		25	
		Cooling capacity	Power input	Cooling capacity	Power input	Cooling capacity	Power input	Cooling capacity	Power input	Cooling capacity	Power input	Cooling capacity	Power input
TWS-MDW4	5	1.031	0.910	0.980	0.954	0.939	0.998	0.908	1.037	0.885	1.097	0.870	1.142
	6	1.061	0.910	1.010	0.956	0.969	1.000	0.939	1.039	0.916	1.098	0.901	1.144
	7	1.092	0.912	1.041	0.958	1.000	1.000	0.969	1.042	0.949	1.100	0.931	1.146
	8	1.125	0.914	1.074	0.958	1.033	1.002	1.003	1.044	0.980	1.104	0.964	1.148
	9	1.158	0.917	1.107	0.960	1.066	1.004	1.036	1.047	1.013	1.105	0.997	1.151
	10	1.196	0.917	1.142	0.961	1.102	1.005	1.071	1.051	1.048	1.109	1.031	1.153



### Corrected Technical Parameters of Water Source Heat Pump Unit under Variable Heating Operating Condition (Underground Water)

Model	Hot water outlet temperature °C	Underground water inlet temperature °C											
		13		14		15		16		17		18	
		Heating capacity	Power input	Heating capacity	Power input	Heating capacity	Power input	Heating capacity	Power input	Heating capacity	Power input	Heating capacity	Power input
TWS-MDW4	40	1.000	0.888	1.035	0.889	1.074	0.889	1.109	0.890	1.147	0.891	1.188	0.893
	43	0.959	0.953	0.994	0.953	1.029	0.953	1.068	0.954	1.103	0.955	1.141	0.956
	45	0.929	0.999	0.965	0.999	1.000	1.000	1.035	1.000	1.074	1.001	1.109	1.002
	48	0.885	1.073	0.918	1.073	0.950	1.073	0.985	1.073	1.024	1.074	1.059	1.075
	50	0.853	1.127	0.885	1.127	0.918	1.127	0.953	1.127	0.985	1.127	1.024	1.127
	55	0.765	1.269	0.794	1.264	0.826	1.264	0.859	1.264	0.891	1.264	0.924	1.264

### Corrected Technical Parameters of Water Source Heat Pump Unit under Variable Cooling Operating Condition (Geothermal)

Model	Chilled water outlet temperature °C	Geothermal water inlet temperature °C													
		10		15		20		25		30		35		40	
		Cooling capacity	Power input	Cooling capacity	Power input	Cooling capacity	Power input	Cooling capacity	Power input	Cooling capacity	Power input	Cooling capacity	Power input	Cooling capacity	Power input
TWS-MDG4	5	1.025	0.767	1.003	0.828	0.973	0.905	0.934	0.997	0.888	1.112	0.833	1.250	0.776	1.408
	6	1.057	0.770	1.036	0.830	1.005	0.906	0.967	0.998	0.921	1.113	0.866	1.250	0.803	1.408
	7	1.096	0.771	1.074	0.833	1.041	0.910	1.000	1.000	0.954	1.113	0.896	1.250	0.836	1.406
	8	1.128	0.775	1.104	0.834	1.074	0.911	1.036	1.002	0.986	1.115	0.929	1.250	0.866	1.406
	9	1.169	0.778	1.142	0.837	1.109	0.914	1.068	1.005	1.019	1.117	0.962	1.252	0.899	1.406
	10	1.178	0.781	1.180	0.840	1.148	0.917	1.107	1.006	1.055	1.118	0.997	1.252	0.929	1.408

### Corrected Technical Parameters of Water Source Heat Pump Unit under Variable Heating Operating Condition (Geothermal)

Model	Hot water outlet temperature °C	Geothermal water inlet temperature °C													
		-5		0		5		10		15		20		25	
		Heating capacity	Power input	Heating capacity	Power input	Heating capacity	Power input	Heating capacity	Power input	Heating capacity	Power input	Heating capacity	Power input	Heating capacity	Power input
TWS-MDG4	40	0.569	0.899	0.718	0.894	0.887	0.890	1.074	0.888	1.285	0.889	1.518	0.897	1.764	0.903
	42	0.548	0.946	0.695	0.900	0.859	0.934	1.046	0.930	1.250	0.931	1.479	0.938	1.725	0.944
	45	0.517	1.005	0.657	1.012	0.817	1.004	1.000	1.000	1.197	1.000	1.423	1.004	1.669	1.009
	46	/	/	0.644	1.037	0.803	1.029	0.982	1.024	1.180	1.023	1.401	1.028	1.648	1.036
	48	/	/	0.618	1.089	0.775	1.081	0.947	1.075	1.141	1.073	1.359	1.077	1.606	1.081
	50	/	/	0.595	1.130	0.743	1.133	0.912	1.127	1.102	1.127	1.313	1.127	1.560	1.130
	55	/	/	/	/	0.637	1.267	0.817	1.269	0.993	1.264	1.190	1.269	1.437	1.277

# WATER-COOLED SCROLL CHILLER (HEAT PUMP) Module Dimensions

## TWS20MDC(W/G)4

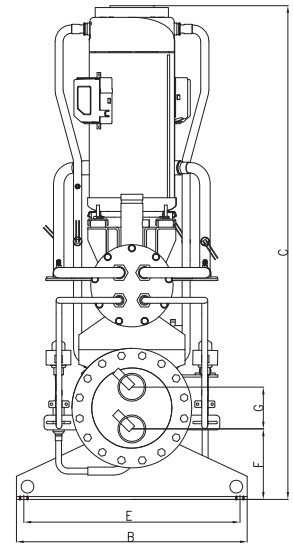
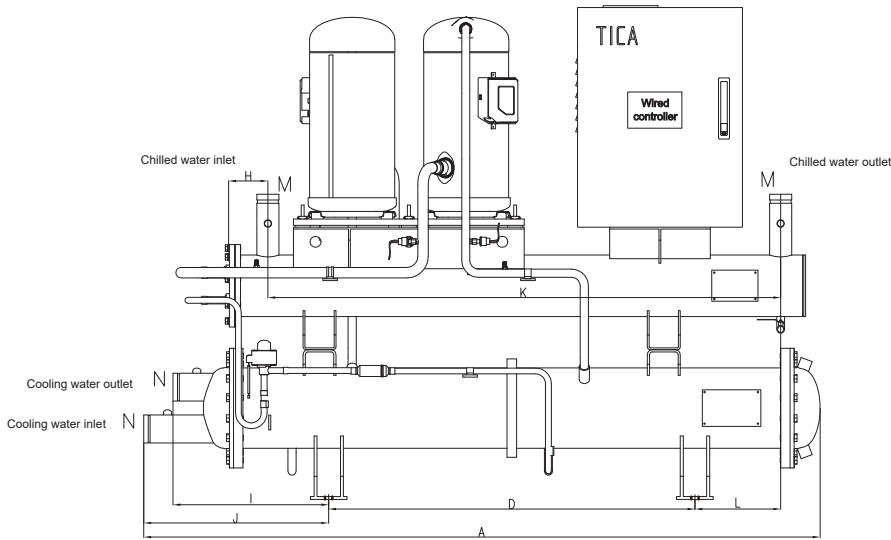

## TWS30MDC(W/G)4

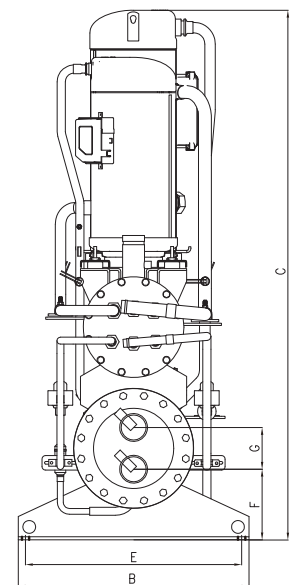
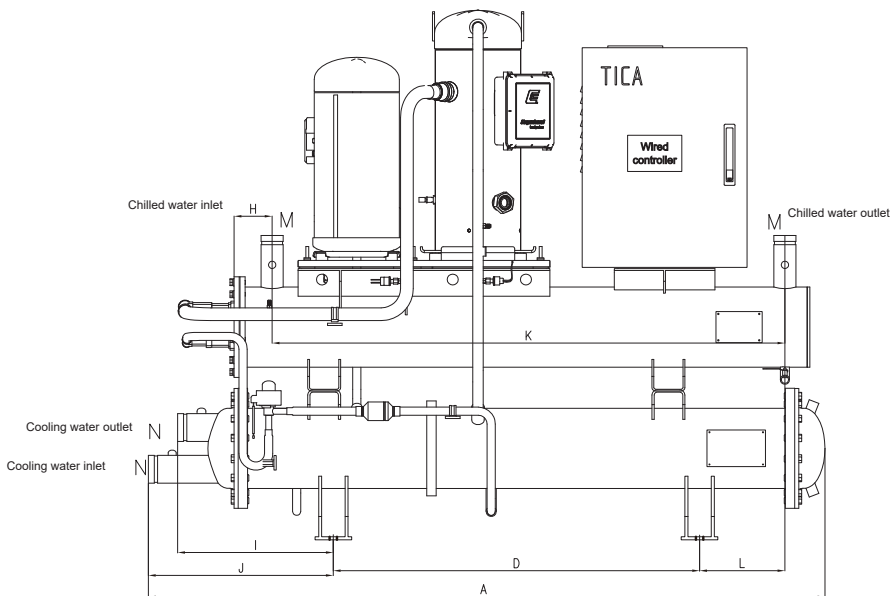

TWS40MDC(W/G)4

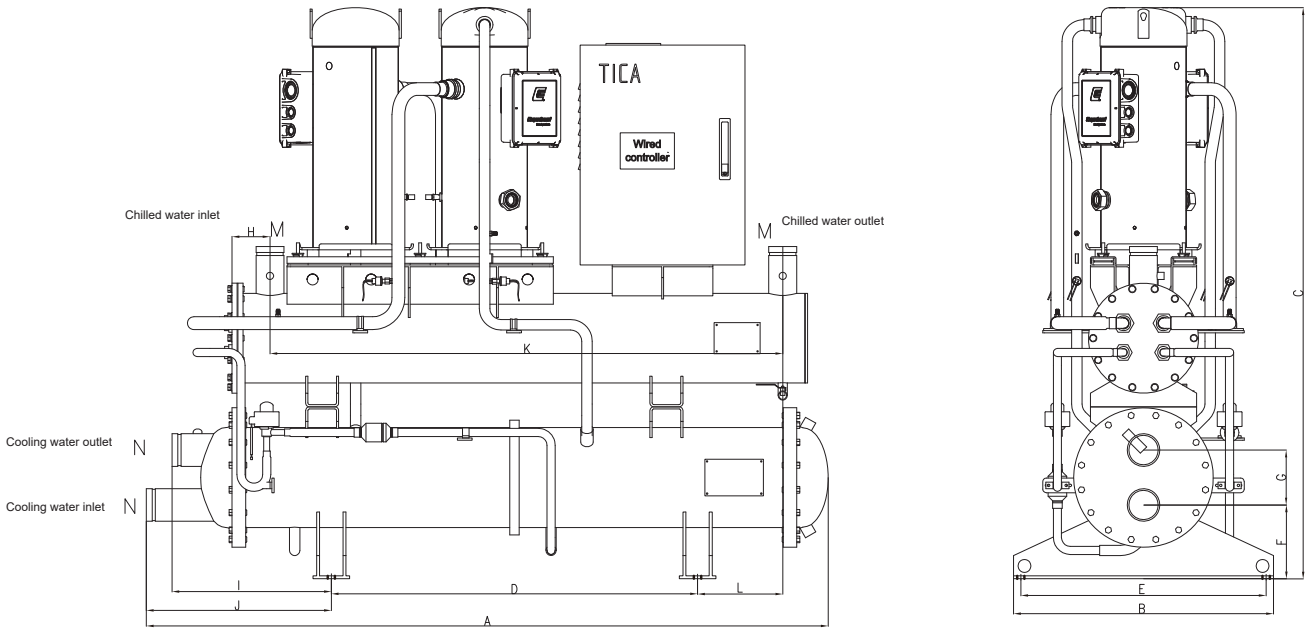

Model	A	B	C	D	E	F	G	H	I	J	K	L	M(DN)	N(DN)
TWS20MDC(W/G)4	1880	660	1380	1000	590	192	114	105	425	505	1400	234	50	65
TWS30MDC(W/G)4	1880	660	1490	1000	590	192	114	105	425	505	1400	234	50	65
TWS40MDC(W/G)4	1900	740	1590	1000	670	202	150	105	435	505	1400	234	65	80

Unit Assembly Diagram

TWS20/30MDC(W/G)4

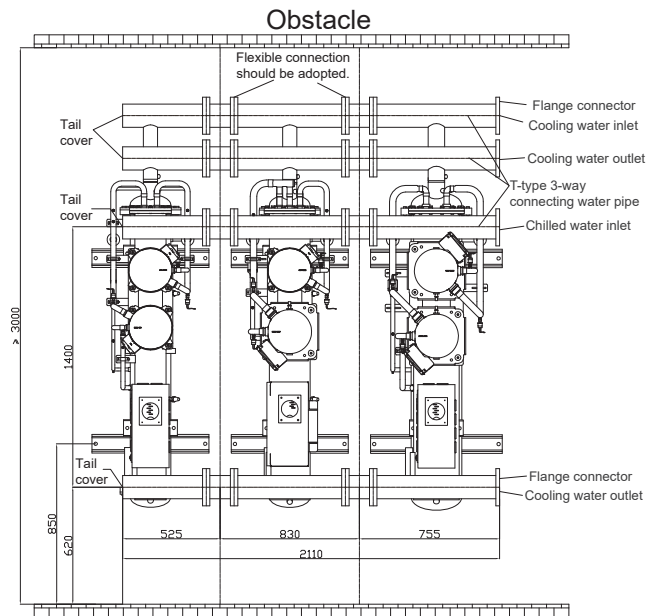

- Notes: 1. The installation side of the water inlet/outlet pipes may be selected according to the actual condition, however, the cooling water inlet/outlet pipes should be installed on the same side, and the same applies to chilled water inlet/outlet pipes.
- 2. Refer to the diagram for the combination of other models.

TWS40MDC(W/G)4

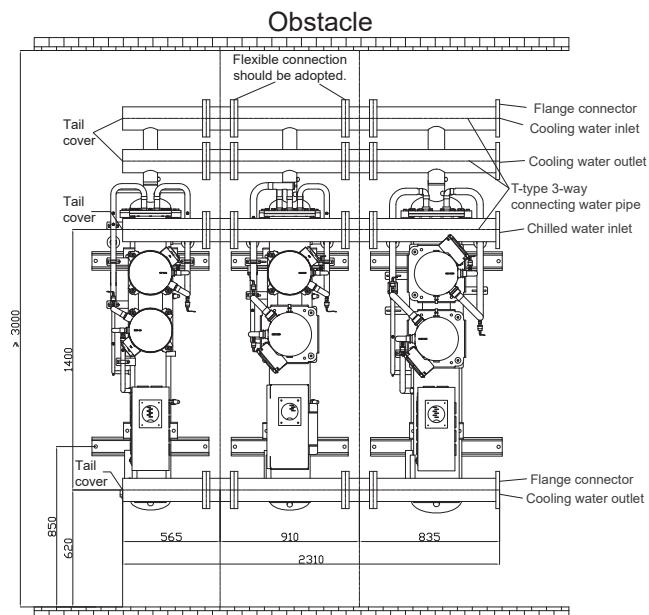

- Notes: 1. Recommended diameter of main water inlet/outlet pipe for 70-160RT units is DN125, direct return installation is recommended
- 2. Recommended diameter of main water inlet/outlet pipe for 160-240RT units is DN150, direct return installation is recommended.
- 3. The installation side of the water inlet/outlet pipes may be selected according to the actual condition; however, the cooling water inlet/outlet pipes should be installed on the same side, and the same applies to chilled water inlet/outlet pipes.
- 4. Refer to the diagram for the combination of other models.



## Position and Dimensions of Installation Foundation

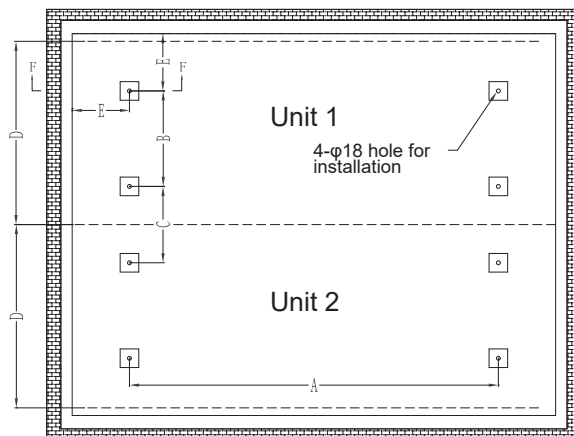

### Position and Dimensions of Installation Foundation (in mm)

Model	A	B	C	D	E
TWS20/30MDC(W/G)4	1000	590	240	830	500
TWS40/MDC(W/G)4	1000	670	240	910	500

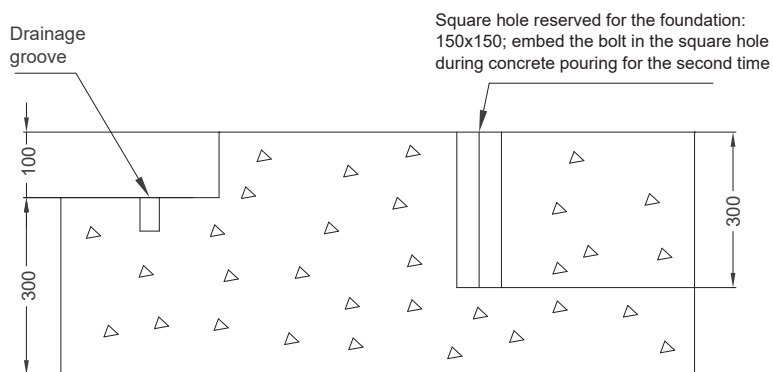

**Profile F-F**

Notes: unit: mm

1. Generally, the unit needs to be installed on a dedicated concrete foundation. In special cases, it can be installed on a rigid base that does not deform (such as channel steel).
2. The concrete foundation or rigid base must bear the weight of the unit when the unit is running.

## Instruction for Use

1. The standard power supply is 380V 3N~50Hz with a maximum voltage deviation of  $\pm 10\%$ . The power supply should be equipped with automatic air switches and power protector;
2. When the unit is used for the first time every quarter, the crankshaft heating box of the compressor must be pre-heated for 12 hours in advance. It is prohibited to start up the unit immediately after power-on;
3. Do not switch the unit frequently. It must not be switched on/off more than 6 times in a hour. the electronic control system needs to be kept from moisture;
4. If the unit is not used for a long time, the water system must be drained to prevent the evaporator from being frozen;
5. The water system should be equipped with an expansion tank; the system circulating water must be clean; the chloride ion content is  $\leq 100\text{PPM}$ ; sufficient water flow should be maintained; and the water filter needs to be cleaned regularly;
6. The water system should have sufficient water to avoid frequent start and stop of the unit and large temperature fluctuations. Generally, the designed water volume is 10L/kW.

## External Water Pipe Connection Diagram of Unit

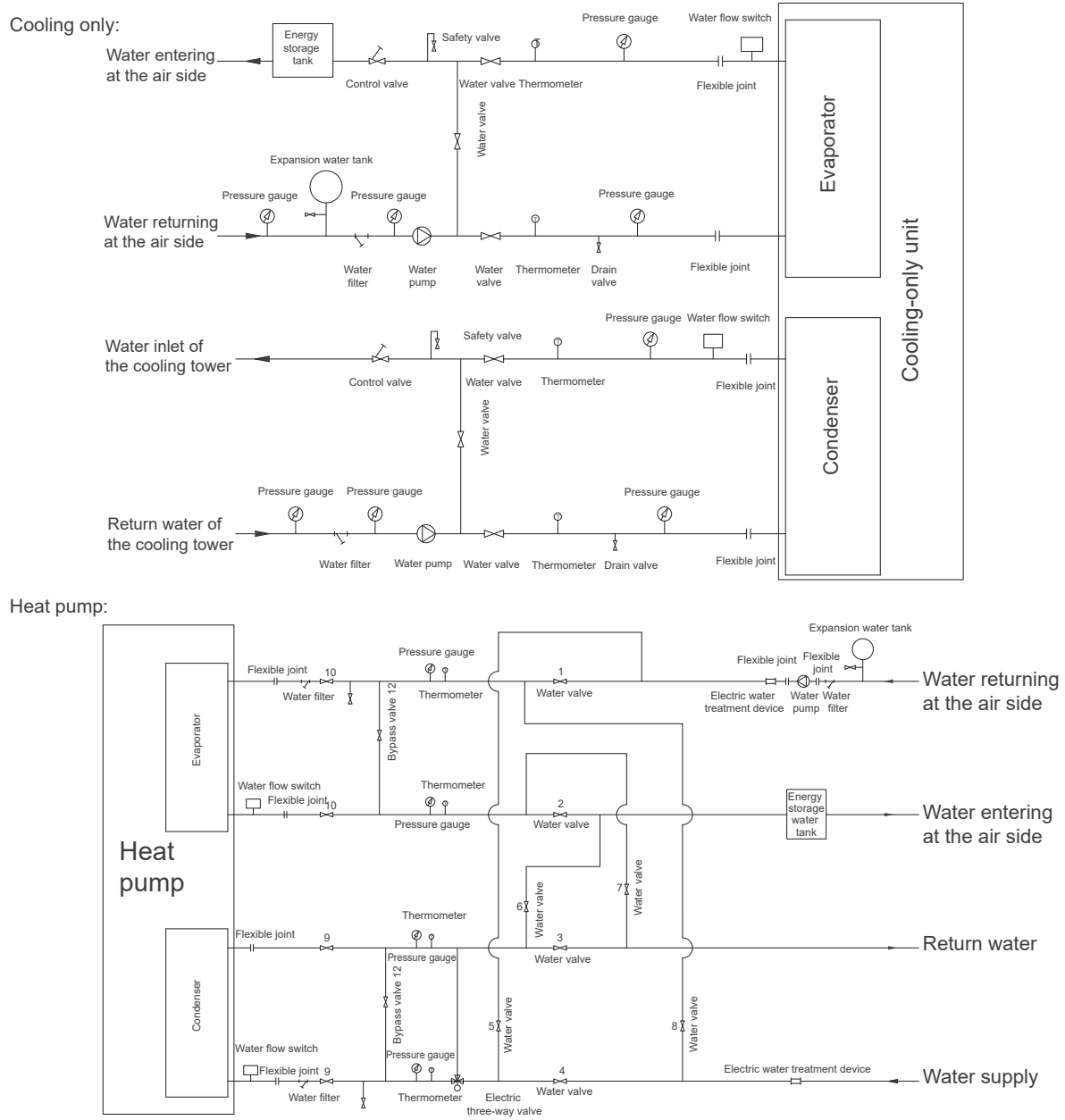

Cooling in summer: valve 1, 2, 3, 4, 9, 10 closed; valve 5, 6, 7, 8 opened  
 Heating in winter: valve 1, 2, 3, 4 closed; valve 5, 6, 7, 8, 9 and 10 opened

**Notes:**

1. Water cycling system shall be designed as simple as possible and avoiding too many elbows. Straight pipes shall be arranged on the same plane where possible.
2. Pay attention to the water inlet and outlet positions of condenser and evaporator lest any connection errors take place.
3. Install manual or automatic air release valve at the top points of water cycling system.
4. Expansion tank shall be anti-corrosive and rust proof and installed at the top points of entire pipeline system.
5. Install a thermometer and a pressure gauge at the chilled and cooling water inlets and outlets respectively.
6. Water drain valves should be installed at the bottom of elbows to make sure the water in the whole unit is emptied.
7. Install check valves at the chilled water and cooling water pipeline connecting the unit heat exchanger to the user's water pipe.
8. Install bypass valves between water inlet and outlet pipes of heat exchanger for future maintenance and pipeline rinsing.
9. Install flexible joints to reduce vibration of pipelines.
10. Install a filter before the water pump because impurities in the water system may cause scale inside the heat exchanger.
11. To boost cooling (heating) performance and save energy, pipelines shall be completely insulated.
12. To prevent frequent breakdowns of the unit caused by too small load, it is recommended to use energy storage tank.



## Five-year Warranty. Quality Assured

We offer a free five-year warranty for TICA standard products manufactured and sold by TICA. For things covered and not covered, please refer to the latest warranty policy we published. In the event of malfunctions or spare parts damages during the free warranty period of TICA products caused by product quality issues (excluding appearance, cleanness and other items subject to environment and climate conditions), the purchaser may obtain a free maintenance service or replacement of the parts (except for consumable parts and materials).

Warranty provider: Local service agency assigned by TICA air conditioning service center

TICA Hotline: 4008-601-601

### Routine maintenance:

TICA recommends the user record the routine operating data of air-conditioning equipment and regularly carry out maintenance.

1. Before using the unit for the first time, check the functioning of the air side equipment and other parts of the water system.
2. (Recommended) Use the following service schedule to maintain the unit:

Daily inspection	1. Check whether the unit generates any alarm						
	2. Check whether the air discharge and air suction pressure and oil pressure are normal						
	3. Check whether the oil level is acceptable (check the oil sight glass to ensure proper amount of oil)						
	4. Check for any abnormal compressor noise						
	5. Check for odors inside the starter and control cabinet						
	6. Check whether the temperature sensor and temperature probe are securely fixed						
	7. Check for any appearance damage of the unit						
	8. Check whether the cooling tower, water pump, and valve are functioning						
	9. Check the appearance of water pipe for damages and leakage						
Monthly inspection	1. Check the color of compressor oil (the oil should be clear and clean; if the color turns dark brown or muddy, replace the oil; if the oil turns black, disassemble and inspect the compressor)						
	2. Check for leakage in the refrigerant loop (whether there is any greasy dirt or sound of leaks)						
	3. Clean the starter and control cabinet						
	4. Check the cleanness of water line filter, and clean the filter when necessary						
	5. Check the water quality, and send the water sample for laboratory analysis if possible (water quality should comply with the standard Code for Design of Industrial Recirculating Cooling Water Treatment or other relevant standard(s))						
Inspection based on service life or runtime		1 years	2 years	3 years	4 years	5 years	Exceptions
		1000 hours	3000 hours	5000 hours	7000 hours	9000 hours	
Compressor	Motor				☆		Insulation resistance during the inspection is abnormal.
	Oil heater	☆	☆	☆	☆	☆	Resistance or insulation is abnormal.
Heat exchanger	Evaporator and condenser		★	☆	★	☆	Temperature difference for heat exchange exceeds 3°C
	Check the water inlet/outlet pressure difference <small>(Refer to the table of technical specifications)</small>	★	★	★	★	★	Water pressure difference is too large or too small. Adjust the water flow until it meets the requirements.
Valves	Solenoid valve	☆	☆	☆	☆	☆	The valve cannot be opened or closed normally.
Electric	Fuse	☆	☆	☆	☆	☆	Disconnection
	Contactor	☆	☆	☆	☆	☆	Serious contact electrocorrosion or noise during running.
	High pressure switch	☆	☆	☆	☆	☆	Controller false alarm.
	Fastening wiring terminal	★	★	★	★	★	The contactor gets loose or can flexibly rotate when turning the connecting cable.
	Checking power supply	★	★	★	★	★	Rated voltage ±10%, phase-to-phase unbalance < 2%.
	Checking phase	★	★	★	★	★	No phase loss or reverse phase

Notes:

- ① ★-----Required maintenance or replacement items; ☆----- Determine the maintenance items according to actual conditions.
- ② Daily and monthly inspections should be performed and recorded by the user.
- ③ The replacement of consumable parts and materials is determined by the service life or operation duration of the unit. For units that operate all year around and those for the purpose of process, the operation duration should prevail; for units under normal operation and those for comfort, the service life should prevail.
- ④ It is recommended that the unit should be fully maintained every three years or every 3,000 hours of machine operation.



Follow WeChat Official  
Account of TICA

# 4008-601-601

---

Address: Hengye Road, Economic and Technological  
Development Zone, Nanjing, China6Postal code:210046  
Tel:86-25-85326977  
E-mail: tica@ticachina.com

---

Note: Due to constant improvement and innovation of TICA's products, the product models, specifications and parameters contained in this document are subject to change without prior notice.